

Service Manual

Cordless Multi Drill & Driver

EY6535-U1

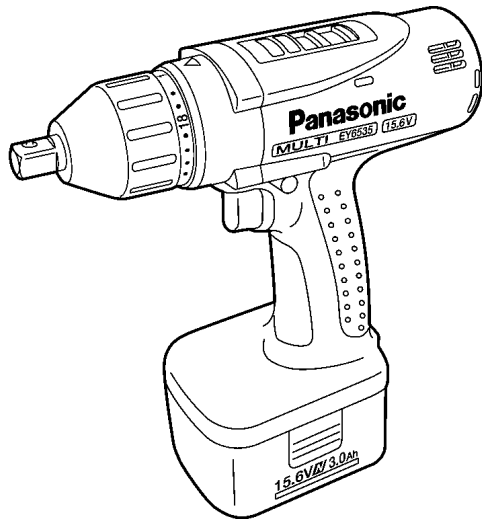

SPECIFICATIONS

		Drill drive mode	Impact mode (Caution: Do not use keyless drill chuck for impact mode.)	
Maximum recommended capacities	Drilling	Wood drilling	ϕ 27mm (1-1/16")	
		Metal drilling	ϕ 13mm (1/2")	
	Screw driving	Machine screw	M5	Not feasible
		Wood screw	ϕ 6.8mm (17/64")	
		Tech screw	ϕ 6.0mm (15/64")	
		Coach screw (Lag bolt)	ϕ 10.0mm (3/8")	
	Bolt fastening		Not feasible	Standard bolt: M12 High tensile bolt: M10
No load speed		0 ~ 650/min (rpm)	0 ~ 2,200/min (rpm)	
Clutch torque		Approx. 1.0Nm (10kgf-cm, 8.7in-lbs.) – 5.4Nm (55kgf-cm, 47.7in-lbs.)	-	
Impact per minute		-	0 ~ 3,300/min (ipm)	
Motor		DC Motor 15.6V		
Square drive		12.7mm (1/2") square drive with pin detent		
Chuck capacity (used by model EY9X003E)		ϕ 1.6 ~ 13mm (1/16" ~ 1/2")	-	
Overall length		216mm (8-1/2")		
Weight (with battery pack)		2.2kg (4.8lbs.)		

Panasonic[®]

© 2001 Matsushita Electric Works Ltd. All rights reserved. Unauthorized copying and distribution is a violation of law.

⚠ WARNING

This service information is designed for experienced repair technicians only and is not designed for use by the general public. It does not contain warnings or cautions to advise non-technical individuals of potential dangers in attempting to service a product. Products powered by electricity should be serviced or repaired only by experienced professional technicians. Any attempt to service or repair the product or products dealt with in this service information by anyone else could result in serious injury or death.

CONTENTS

	Page	Page	
1 SCHEMATIC DIAGRAM	2	5 TROUBLESHOOTING GUIDE	10
2 WIRING CONNECTION DIAGRAM	2	6 EXPLODED VIEW	12
3 DISASSEMBLY INSTRUCTIONS	3	7 REPLACEMENT PARTS LIST	13
4 ASSEMBLY INSTRUCTIONS	6		

1 SCHEMATIC DIAGRAM

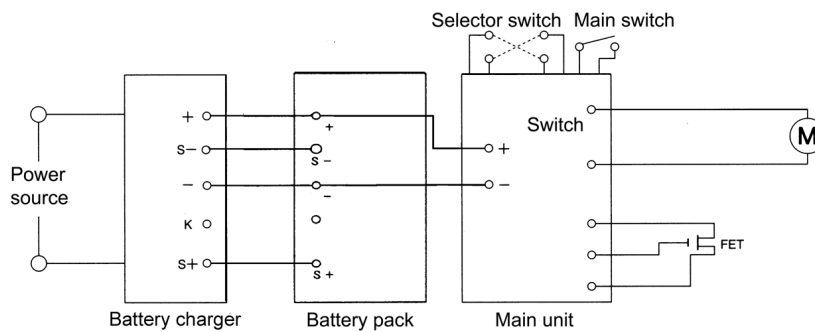

2 WIRING CONNECTION DIAGRAM

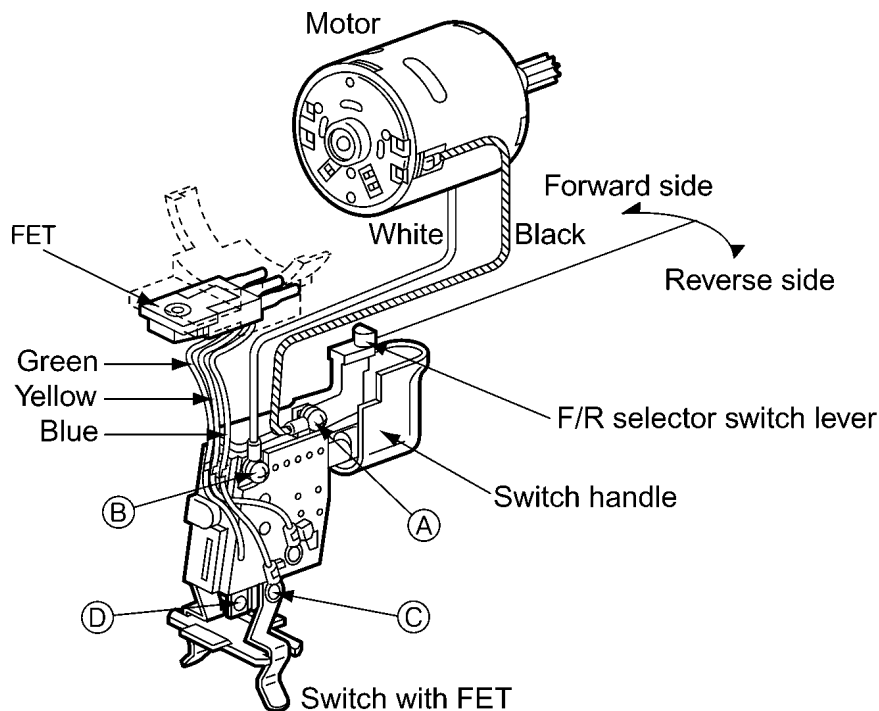

3 DISASSEMBLY INSTRUCTIONS

■ HOW TO DISASSEMBLE THE MAIN UNIT.

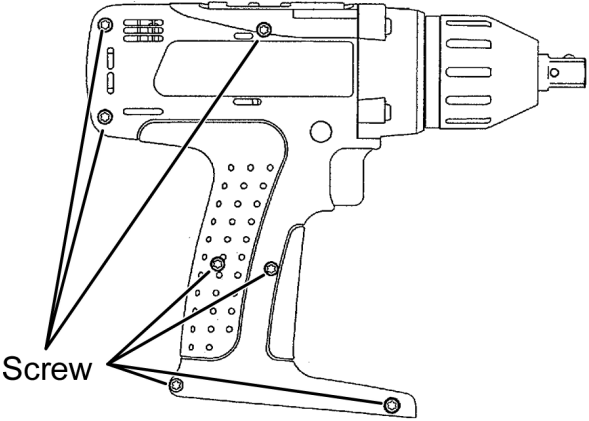
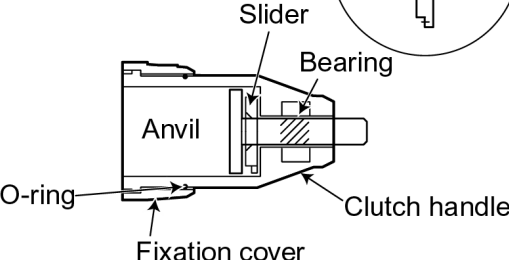
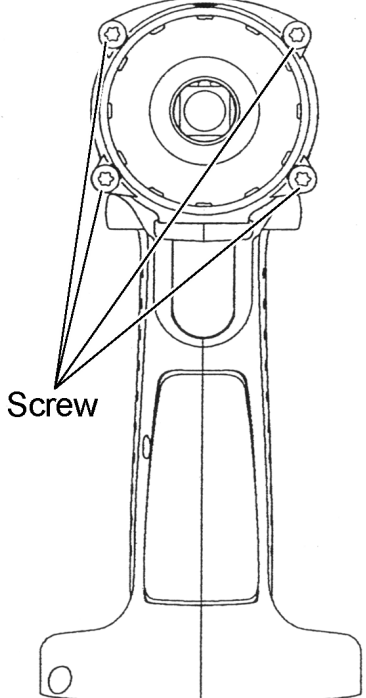
Ref. No. 1A	Procedure 1A	Removal of Fixation Cover and Housing.
 <p>Screw</p>	 <p>Slider Bearing Anvil O-ring Clutch handle Fixation cover</p>	 <p>Screw</p> <ol style="list-style-type: none"> 1. Remove 4 screws tightened with the fixation cover and take it out. 2. Remove clutch handle, slider and anvil. 3. Remove 7 housing screws. 4. Remove the click springs and separate housing A and B.

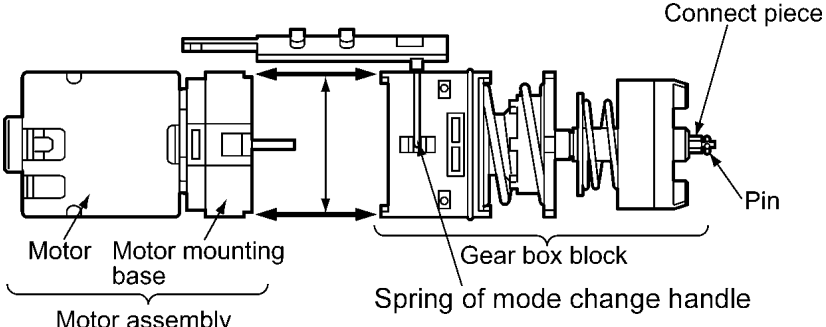
Ref. No. 1B	Procedure 1A → 1B	Disassembly of Motor and Gear Box Block.
 <p>Motor Motor mounting base Motor assembly Gear box block Spring of mode change handle Connect piece Pin</p>		<ol style="list-style-type: none"> 1. Remove the motor assembly with the gear box block from the housing. 2. Separate the motor assembly from the gear box block by twisting the motor to unlock tabs.

Ref. No. 1C

Procedure 1A → 1B → 1C

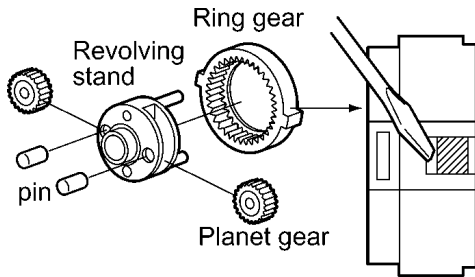
Removal of Motor Mounting Base.

1. To remove the ring gear, unhook right and left side of the projections using a flat screwdriver.
2. After removing the ring gear, the internal parts can be remove one after another.
3. Loosen 3 screws tightened with the motor mounting base.

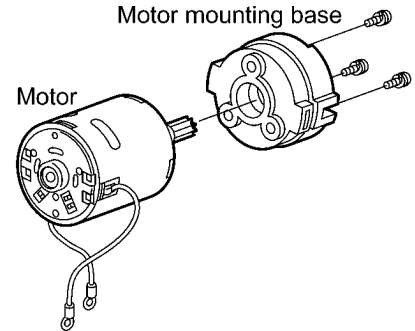

Ref. No. 1D

Procedure 1A → 1B → 1D

Removal of Gear Box Assembly.

1. Hold the driving carrier as illustrated. Compress the assembly and remove the pin.
2. Take out the driving shaft assembly and the gear case assembly from the shaft of the driving carrier.

NOTE :

Make sure not to lose the pin and the connect piece.

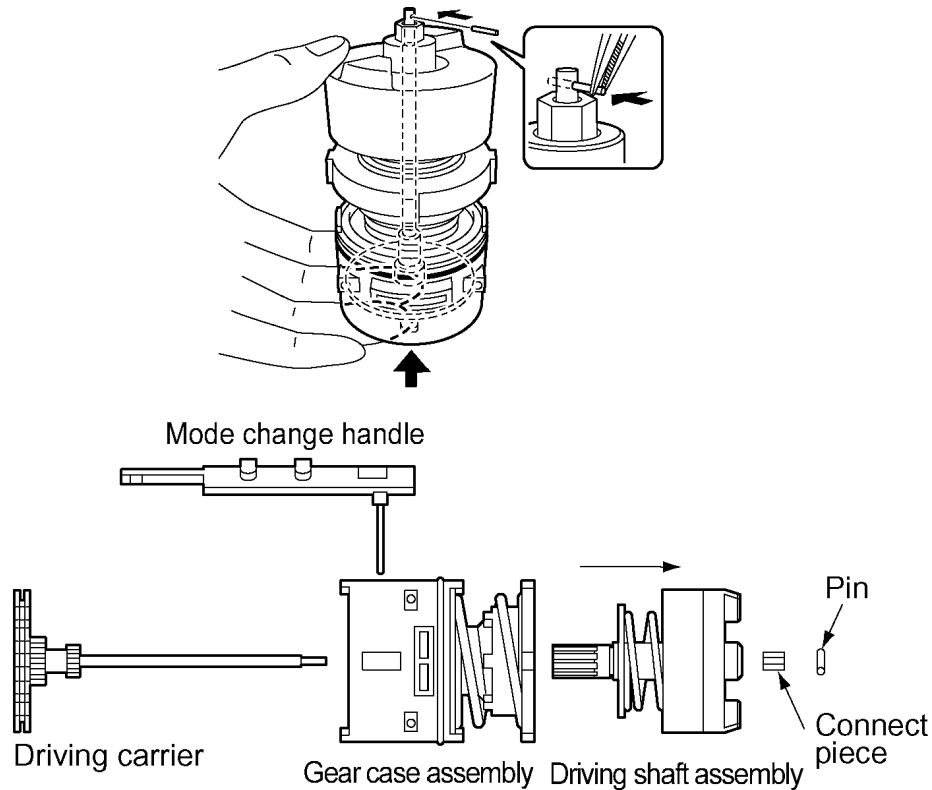

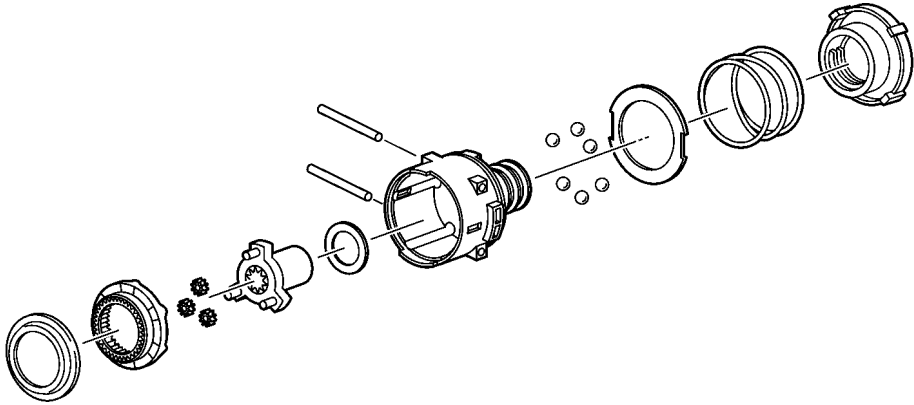
Ref.No.1E	Procedure 1A → 1B → 1D → 1E	Removal of Gear Case Assembly.
		<ol style="list-style-type: none">1. Take out the mode change handle.2. Pull out 2 pins (ϕ 2.5×33.6).3. After removing pins, the internal parts of the gear case assembly can be removed one after another. thrust plate → clutch gear → planet gear (3pcs) → carrier → thrust plate4. Remove adjusting screw, clutch spring, and clutch plate.5. After removing the clutch plate, 6 pieces of steel ball come off.
		

4 ASSEMBLY INSTRUCTIONS

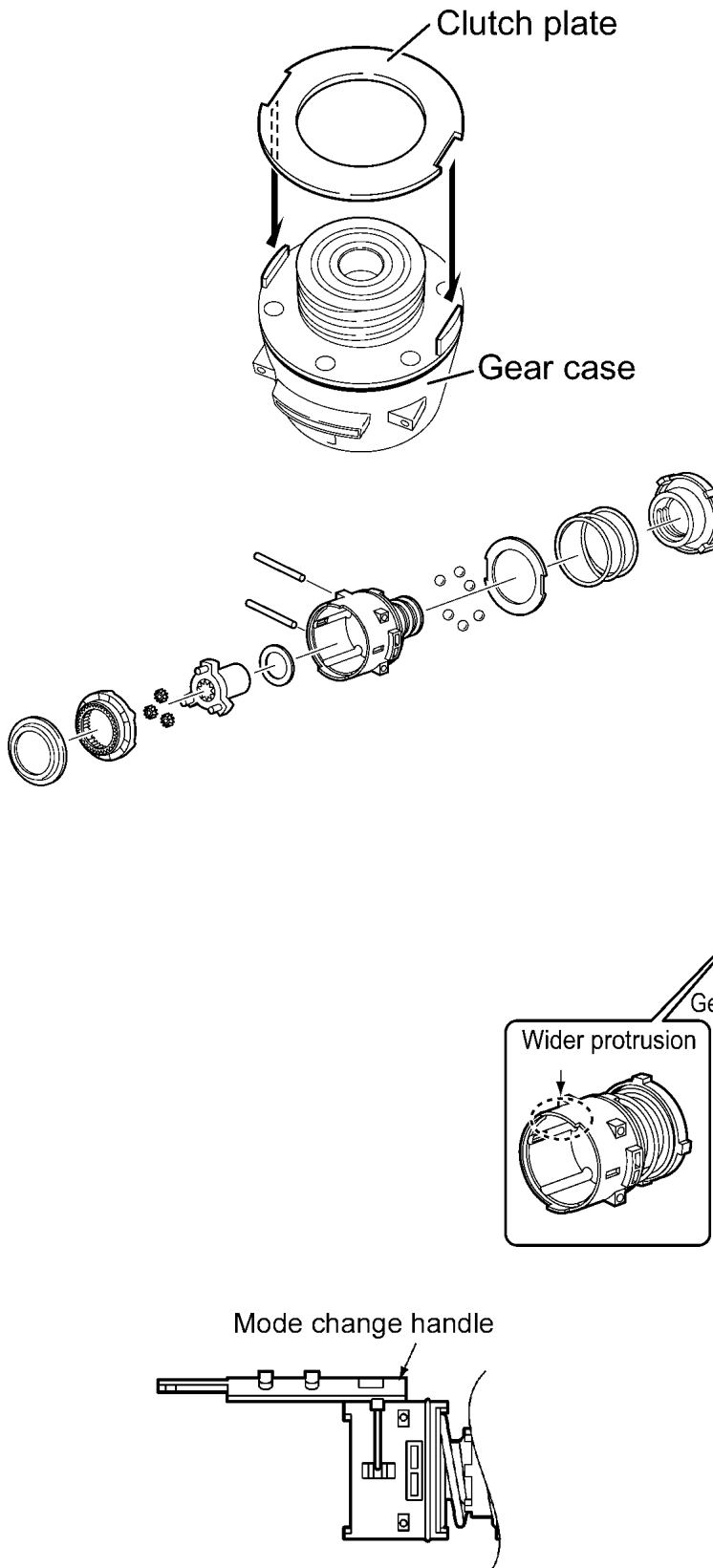
Ref.No.2A	Procedure 2A	Assembly of Gear Case Block.
 <p style="text-align: center;">Clutch plate</p> <p style="text-align: center;">Gear case</p> <p style="text-align: center;">Gear case assembly</p> <p style="text-align: center;">Wider protrusion</p> <p style="text-align: center;">Wider protrusion(6mm)</p> <p style="text-align: center;">Mode change handle</p>		<ol style="list-style-type: none"> 1. Assemble thrust plate, clutch gear, planet gear (3pcs), carrier, thrust plate and insert pins (2pcs). 2. Reinstall one piece of steel ball into each of 6 holes. 3. Assemble clutch plate and clutch spring. 4. Align the widest protrusion of adjusting screw with the narrower protrusion of gear case. 5. Turn the adjusting screw into the gear case assembly one rotation for clockwise direction. 6. Set the mode change handle on the wider protrusion of gear case. 7. Confirm proper position of the mode change handle that both ends of spring must be put into the grooves of the driving carrier.

Ref.No.2B

Procedure 2A→2B

Assembly of Motor Mounting Base.

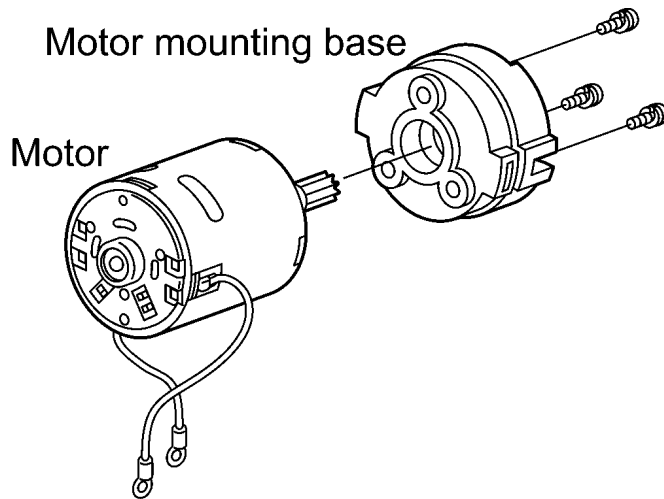
**NOTE :**

After loosening these screws, please replace them with new screws. The old screws have an adhesive that can not be reapplied. New screws are identified with blue adhesive.

1. Tighten 3 screws of the motor mounting base.
2. Assemble planet gears and pins with the revolving stand and insert them into the motor mounting base.
3. The ring gear has its own correct direction. Confirm the direction when the ring gear is inserted into the motor mounting base.
4. Adjust the protrusion parts of ring gear with the groove parts of motor mounting base.

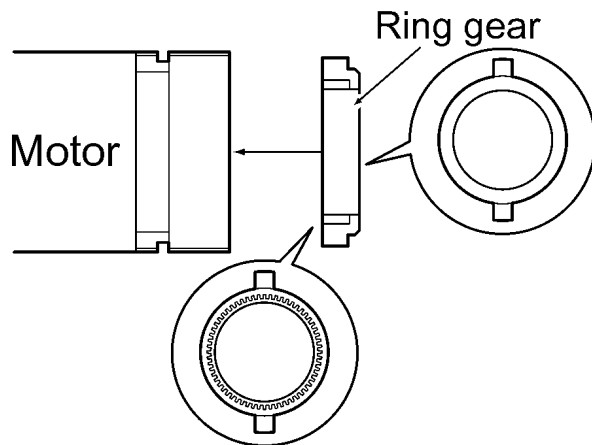
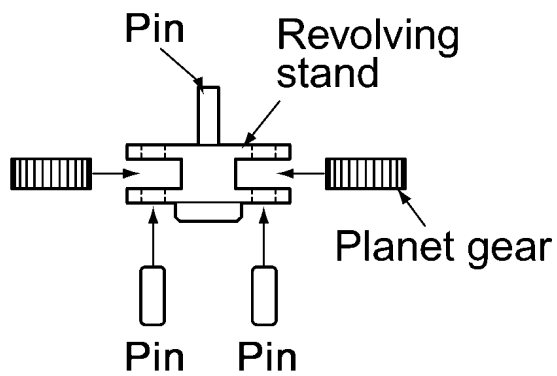

Ref.No.2C

Procedure 2A→2B→2C

Assembly of Gear Box Assembly.

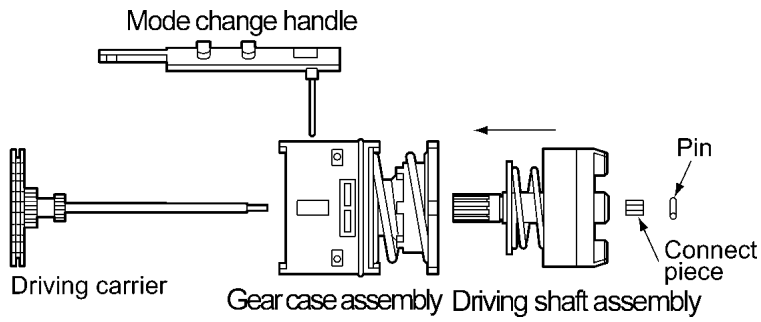

1. Fit the driving carrier into the hole of the gear case assembly and the driving shaft assembly.
2. Confirm the connect piece is inside of the driving shaft block.
3. Insert the pin into the shaft of the driving carrier holding the bottom of the gear box assembly (driving carrier) by hand.
4. Align the wider protrusion of motor mounting base with the wider protrusion of gear case.

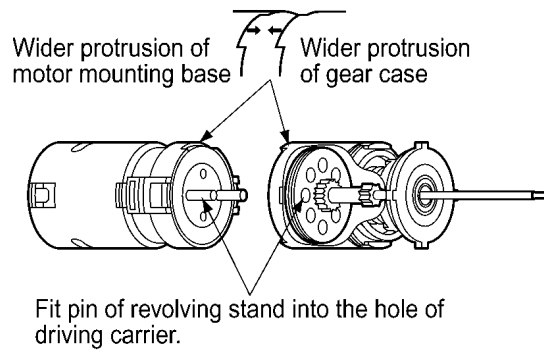
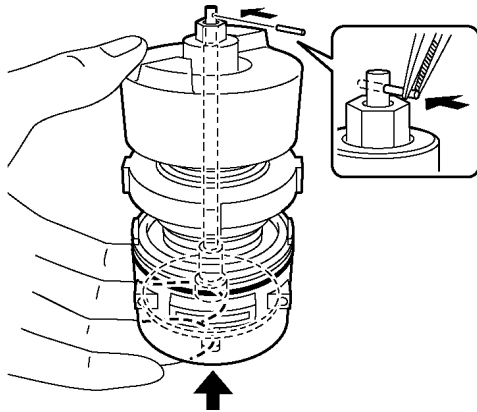

Ref.No.2D

Procedure 2A→2B→2C→2D

Assembly of Motor and Switch.

1. Fit terminal of lead wire (black) parallel to the heat sink.

Caution:

Be careful that the heat sink and the terminal do not touch, otherwise these are shortcircuit.

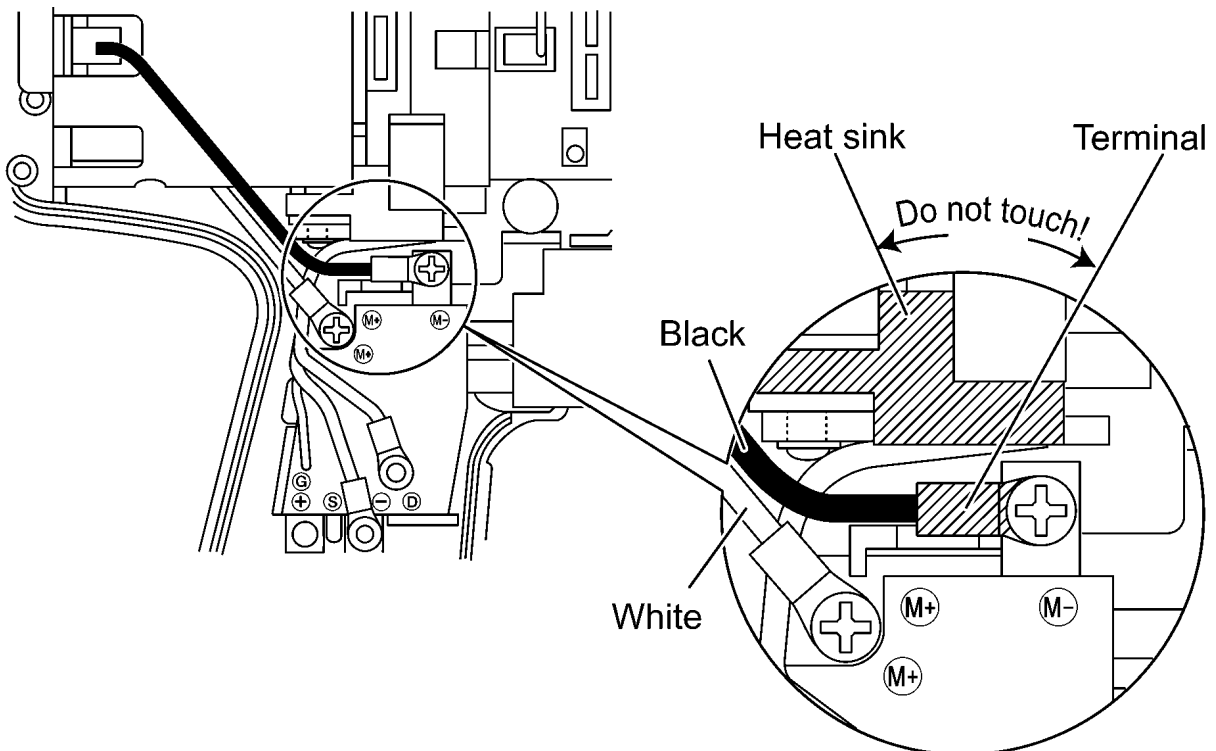

Ref.No.2E

Procedure 2A→2B→2C→2D→2E

Assembly of Housing.

1. Confirm proper position of the click springs and the position in each housing A and B.
2. Check that the widest protrusion (6mm) of adjusting screw is in the middle and the mode change handle is set to the IMPACT position.
3. Set anvil and slider, has its own correct direction. Confirm the direction when assembling.
4. Set the clutch handle with position 1 on top.
5. When setting fixation cover, align Δ mark on top.
6. Tighten 4 screws.

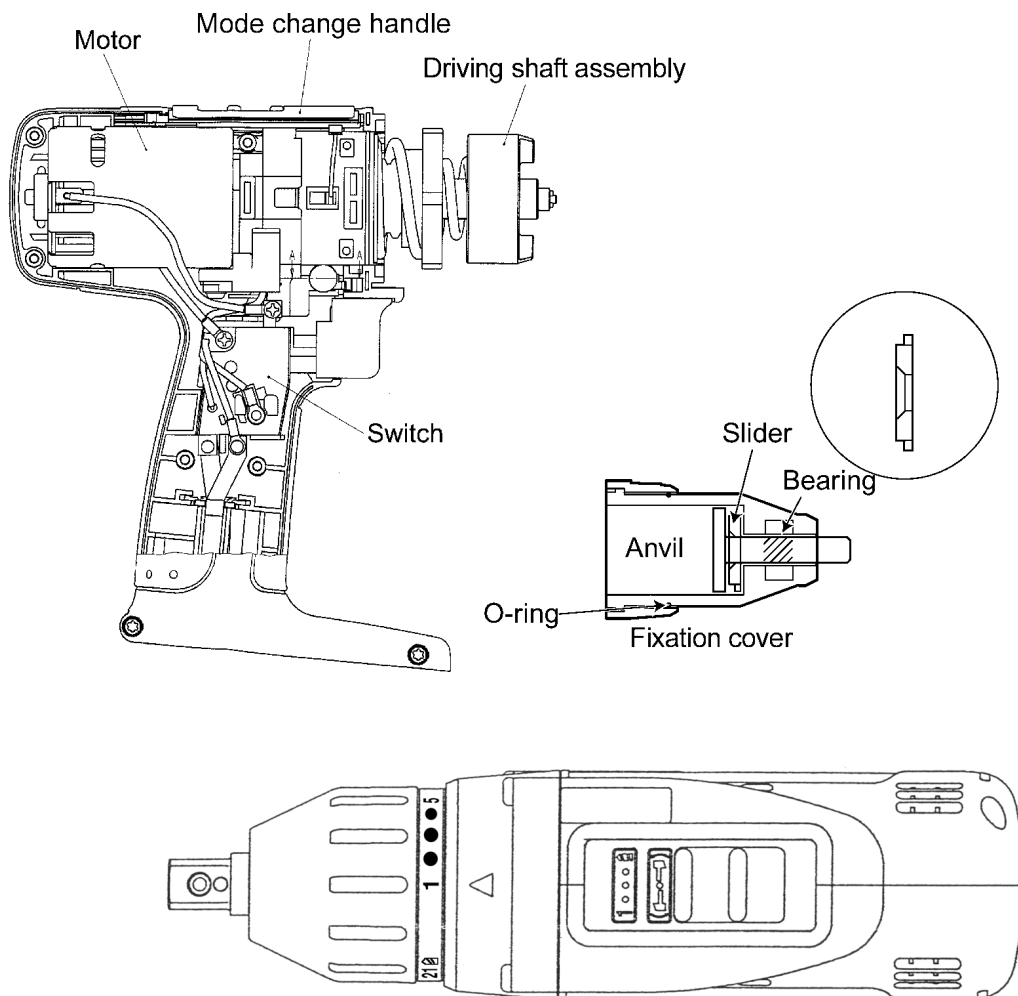
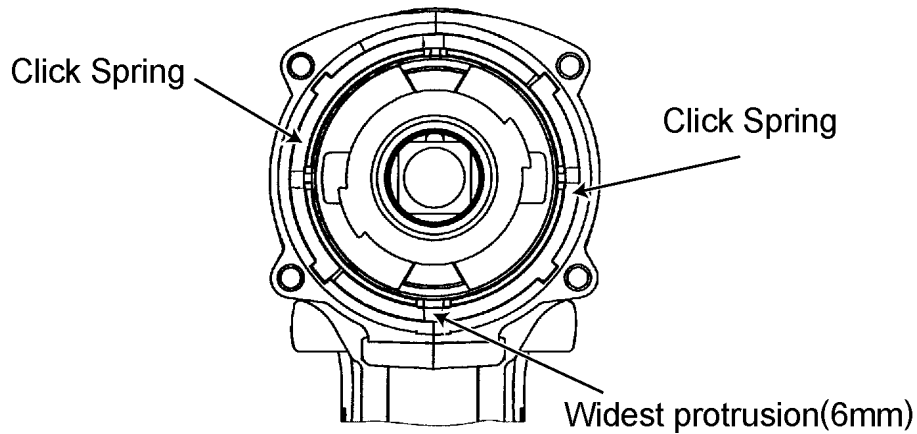

5 TROUBLESHOOTING GUIDE

(Refer to WIRING CONNECTION DIAGRAM)

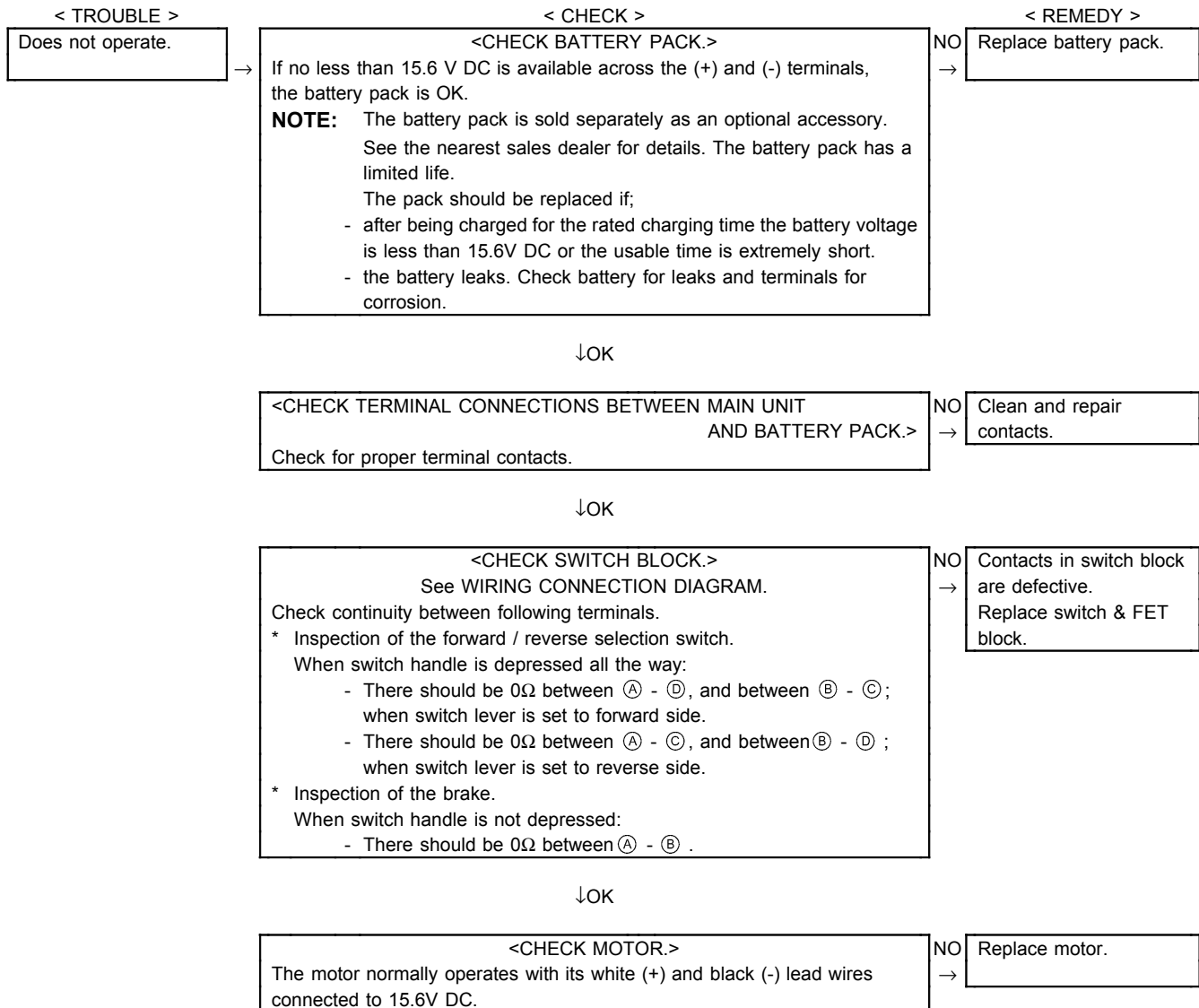

< TROUBLE >
No speed-control.

< CHECK >
<CHECK FET.>

Even if FET block is defective, it can not be replaced individually. Replace whole switch block.
Shortcircuit (G: gate) and (S: source), and measure between it and (D: drain) with switch block.

NOTE:
* FET is sensitive against static electricity.
** The resistance value will vary dependent upon the measurement range of the tester.

	Volt-Ohm meter		Measurement Value
	(+)	(-)	
Terminal	(D)	(G)(S)	$\infty \Omega$
	(G)(S)	(D)	few resistance(**)

< REMEDY >
NO → Replace switch & FET block.

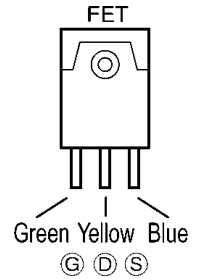

↓OK

<CHECK SWITCH BLOCK.>

NO → Replace switch & FET block.

Weakness of vibration.

<CHECK ANVIL.>

Check wear condition. If no less than 1mm from the corner at (A) side or 0.5mm from the corner at (B) side, anvil is OK.

Anvil

Check wear condition

A B 1mm 0.5mm

NO → Replace anvil.

↓OK

<CHECK HAMMER BLOCK.>

Check whether hammer block rotates smoothly when moving shaft of hammer.

NO → Replace driving shaft assembly.

↓OK

<CHECK MOTOR.>

Measure no load rotation whether it is more than 1,900rpm with full charged battery pack.

NO → Replace motor.

6 EXPLODED VIEW

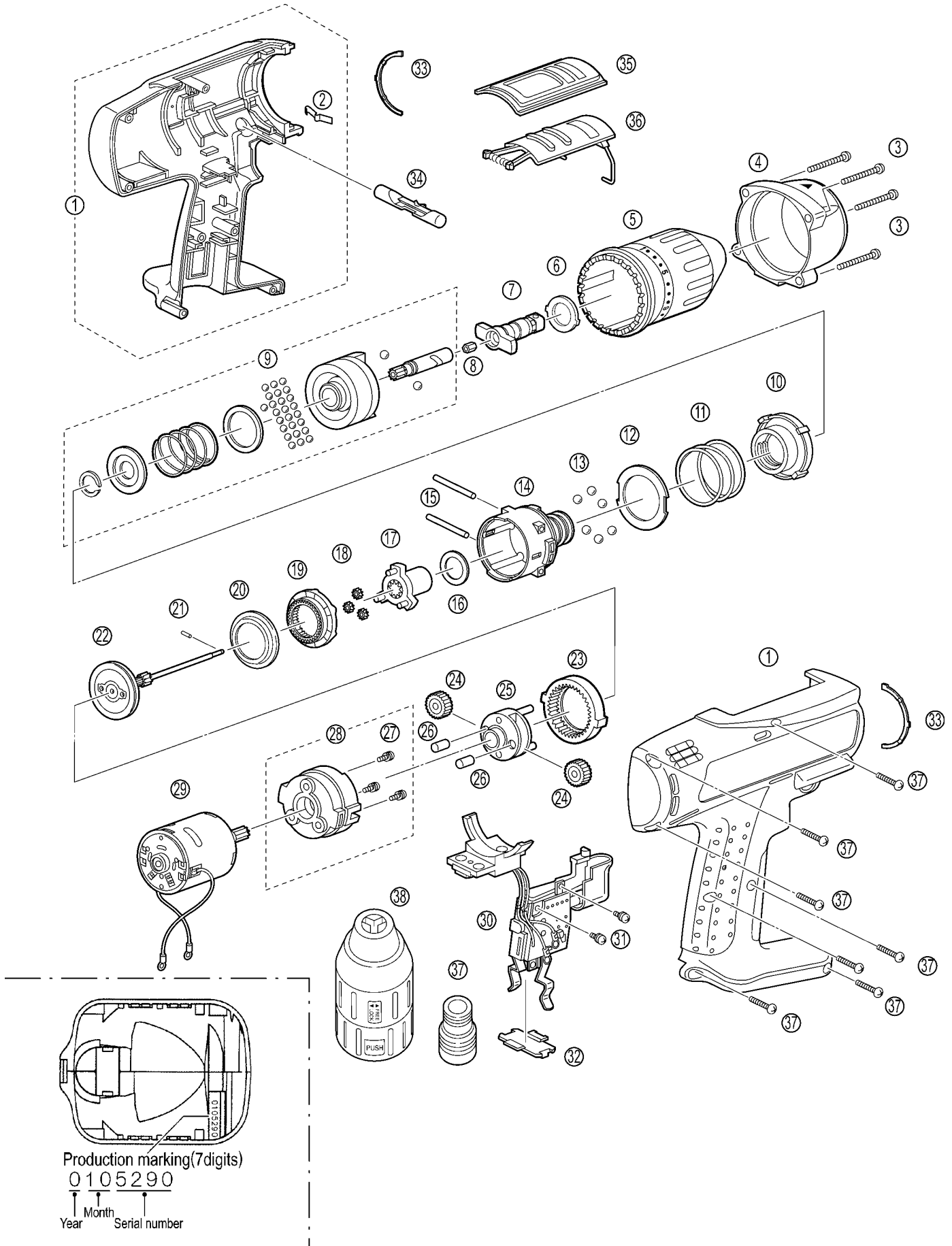

7 REPLACEMENT PARTS LIST

NOTE:

*A = available as an optional accessory

*B = only available as set

*C = available individually

Ref. No.	Part No.	Part Name & Description	Remarks		Per Unit
1	WEY6535K3078	HOUSING AB SET			▲ 1
2	EY6481L0177	CLICK SPRING			▲ 1
3	WEY6535K9158	SCREW	*C	4×25	▲ 4
4	WEY6535S0648	FIXATION COVER			▲ 1
5	WEY6535K3748	CLUTCH HANDLE			▲ 1
6	WEY6535L0868	SLIDER			▲ 1
7	WEY6535L1128	POWER SHAFT			▲ 1
8	WEY6535L0888	CONNECT PIECE			▲ 1
9	WEY6535L1418	DRIVING SHAFT ASSEMBLY			▲ 1
10	WEY6535L0638	ADJUSTING SCREW			▲ 1
11	WEY6535L0168	CLUTCH SPRING			▲ 1
12	WEY6535L0578	CLUTCH PLATE			▲ 1
13	WEY6535L6968	STEEL BALL	*B	φ 5 , (6PCS/PACK)	▲ 6
14	WEY6535L1068	GEAR CASE			▲ 1
15	EY6481L0357	THRUST PIN 2.5×33.6	*B	2.5×33.6, (2PCS/PACK)	▲ 2
16	WEY6535L0928	THRUST PLATE			▲ 1
17	WEY6535L1648	CARRIER			▲ 1
18	WEY6505L1347	PLANET GEAR	*B	(3PCS/PACK)	▲ 3
19	WEY6535L1358	CLUTCH GEAR			▲ 1
20	WEY6535L0908	THRUST PLATE			▲ 1
21	WEY6535L0918	PIN		1×5.5	▲ 1
22	WEY6535L1368	DRIVING CARRIER			▲ 1
23	WEY6505L1457	RING GEAR			▲ 1
24	WEY6505L1377	PLANET GEAR A	*B	(2PCS/PACK)	▲ 2
25	WEY6535L1388	REVOLVING STAND			▲ 1
26	WEY6505L0367	PIN	*C	φ 5×9.4	▲ 2
27	WEY6505L9007	SCREW	*B	K3×6, (3PCS/PACK)	▲ 3
28	WEY6535L0028	MOTOR MOUNTING BASE			▲ 1
29	WEY6535L1008	DC MOTOR			▲ 1
30	WEY6535Y2008	SWITCH			▲ 1
31	EY6230L6037	SEMS SCREW	*C	M3×5	▲ 2
32	EY6230L0207	DUST PREVENTIVE PLATE			▲ 1
33	WEY6535L0188	CLICK SPRING	*B	(2PCS/PACK)	▲ 2
34	EY6402Y3247	SELECTOR HANDLE			▲ 1
35	WEY6535X3248	D/I INDICATION COVER			▲ 1
36	WEY6535K3238	D/I CHANGE HANDLE			▲ 1
37	WEY6930K9218	SCREW	*C	3×20	▲ 7
-	WEY6535K8108	OPERATING INSTRUCTIONS			▲ 1

** Battery Pack, Keyless Chuck, Quick Change Chuck and Tool Case are available as an optional accessory. " See the nearest sales dealer for details.

*** For replacement parts of charger, see the charger service manual.